

## HIGH QUALITY DESKTOP DISPLAYS

The 19LM121A61MY Series of LCD monitor heads has been designed for industrial applications that require a compact, SVGA compatible monitor with good viewability. Once set, via the Autosetup facility, there is no need for user adjustments and there are no front controls.

The 19LM121A61MY Series incorporates RGB capability, opening applications in security, surveillance and machine vision systems. With AC power supplies integrated within the base of the desktop stand, considerable force is required to unbalance them. This makes them ideal for Touchscreen applications on industrial desks. The display head is also available separately for arm mounting applications – see 29LM head monitor series.

### SOLUTIONS FOR DESKTOP MONITORS

- > **A No Frills Industrial Design Concept**  
A heavy - duty tiltable desktop stand with automatic image size adjustment
- > **Touch screen capability**  
A touch screen can be easily integrated into the display
- > **Inputs**  
All monitors have 15-D and DVI-D connectors
- > **Rugged metal construction with good stability**  
The LCD monitor has been designed with solidity, being housed in a compact metal construction with a toughened glass protection screen.





# 12.1" DESKTOP LCD MONITOR

19LM121A61MY

# DATASHEET

FRONT VIEW

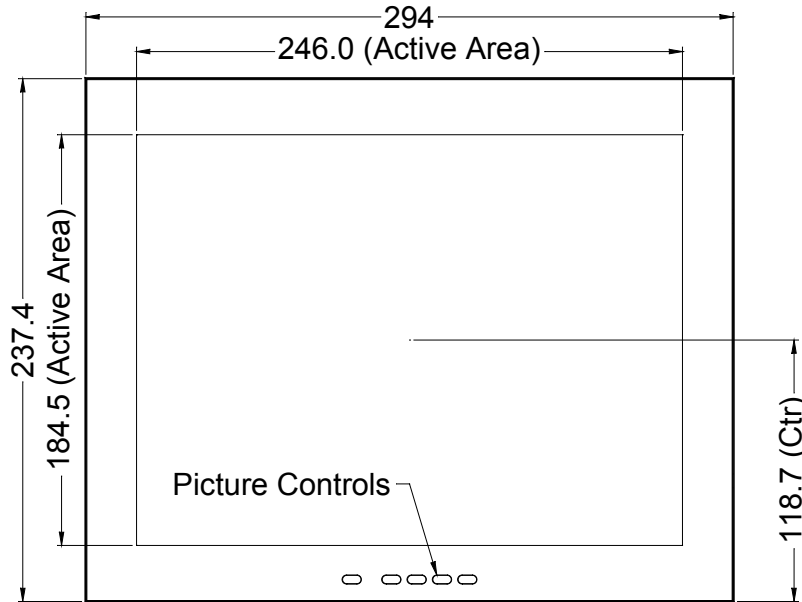

SIDE VIEW

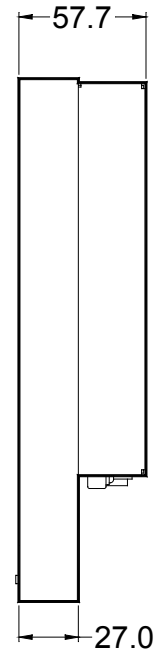

REAR VIEW

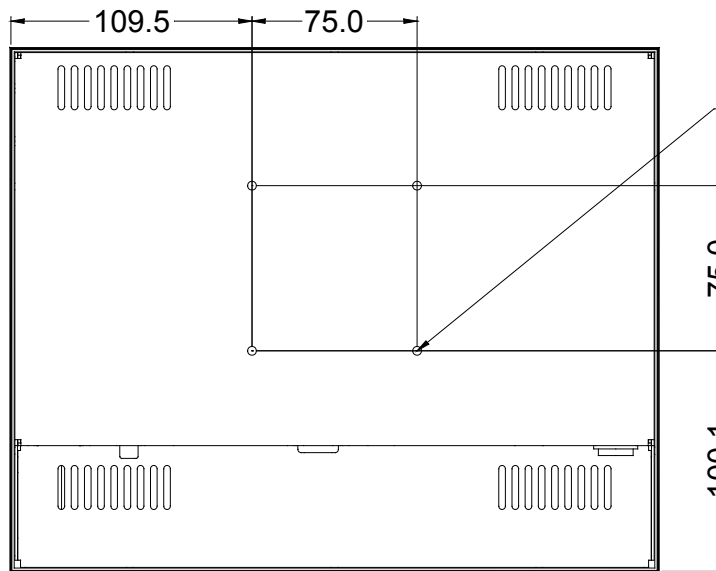

4xM4 Fixings on VESA Standard spacing

\*Where fitted

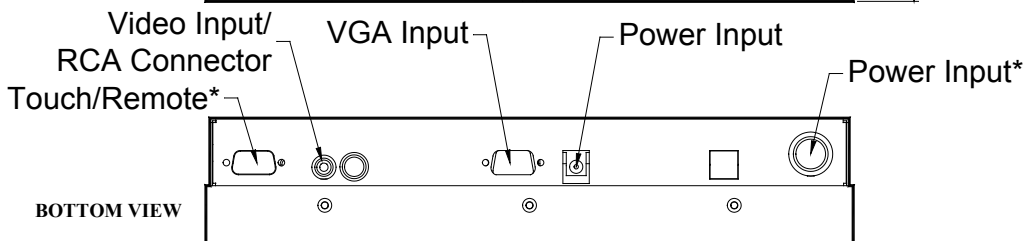

All dimensions in millimetres  
(Not to scale)